

KINOVA

Achieve Extraordinary

KINOVA™ *Ultra lightweight robotic arm*

6 DOF

Specifications



Tech Specs

KINOVA™
Ultra lightweight
robotic arm

6 DOF

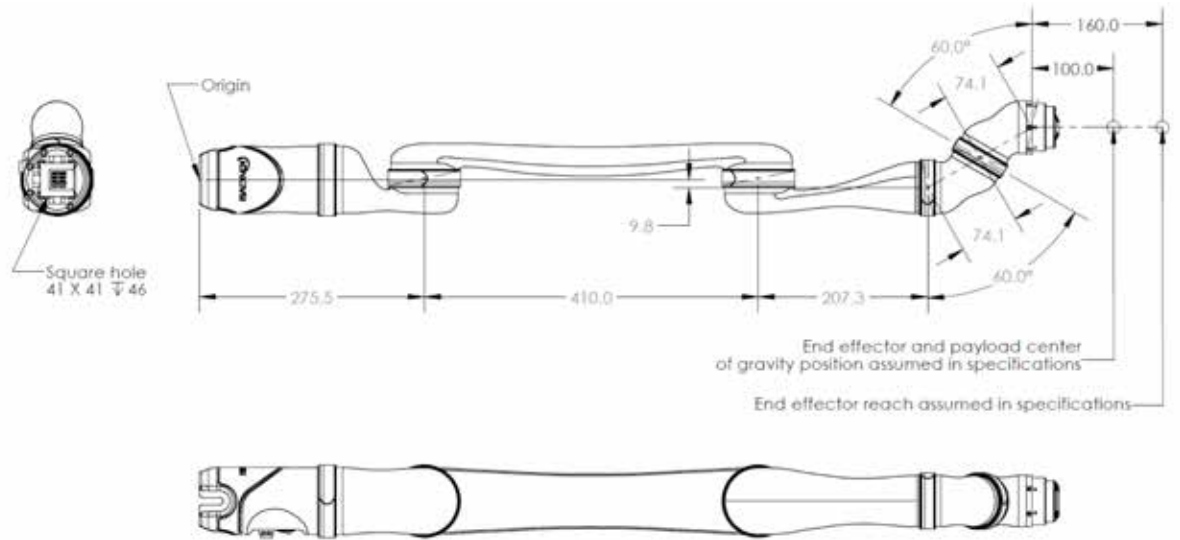

GENERAL

| | | NO GRIPPER | 2 FINGERS (KG-2) | 3 FINGERS (KG-3) |
|--|---------------------------|---|------------------|------------------|
| Total weight | | 4.4 kg | 5.0 kg | 5.2 kg |
| Payload capabilities | Mid-range continuous | 2.6 kg | 1.8 kg | 1.6 kg |
| | Full-reach peak/temporary | 2.2 kg | 1.5 kg | 1.3 kg |
| Materials | Links | Carbon fiber | | |
| | Actuators | Aluminum | | |
| Maximum reach | | 90 cm | | |
| Joint range after start-up <small>(software limitation)</small> | | ±27.7 turns | | |
| Maximum linear arm speed | | 20 cm/s | | |
| Power supply voltage | | 18 to 29 VDC, 24 VDC nominal | | |
| Peak power | | 100 W | | |
| Average power | Operating mode | 25 W | | |
| | Standby mode | 5 W | | |
| Communication protocol | | RS-485 | | |
| Communication cables | | 20 pins flat flex cable | | |
| Expansion pins | | 2 <small>(on communication bus)</small> | | |
| Water resistance | | IPX2 | | |
| Operating temperature | | -10 °C to 40 °C | | |

CONTROLLER

| | | |
|---------------------------------|-----------------------|------------------------------|
| Ports | Joystick | 1 Mbps Canbus |
| | Power supply | 18 to 29 VDC, 24 VDC nominal |
| | USB 2.0 (API) | 12 Mbps |
| | Ethernet (API) | 100 Mbps |
| Control system frequency | High level (API) | 100 Hz |
| | Low level (API) | Up to 500 Hz |
| CPU | | 360 MHz |
| SDK | APIs | High and low level |
| | Compatibility | Windows, Linux Ubuntu & ROS |
| | Port | USB 2.0, Ethernet |
| | Programming languages | C++ |
| Control | | Force, cartesian & angular |

SPECIFICATIONS

| | |
|----------------------------------|--------|
| Actuators #1, #2 & #3 | KA-75+ |
| Actuators #4, #5 & #6 | KA-58 |

KINOVA

Achieve Extraordinary

KINOVA™ *Ultra lightweight robotic arm*

7 DOF Spherical

Specifications



Tech Specs

KINOVA™
Ultra lightweight
robotic arm

7 DOF Spherical

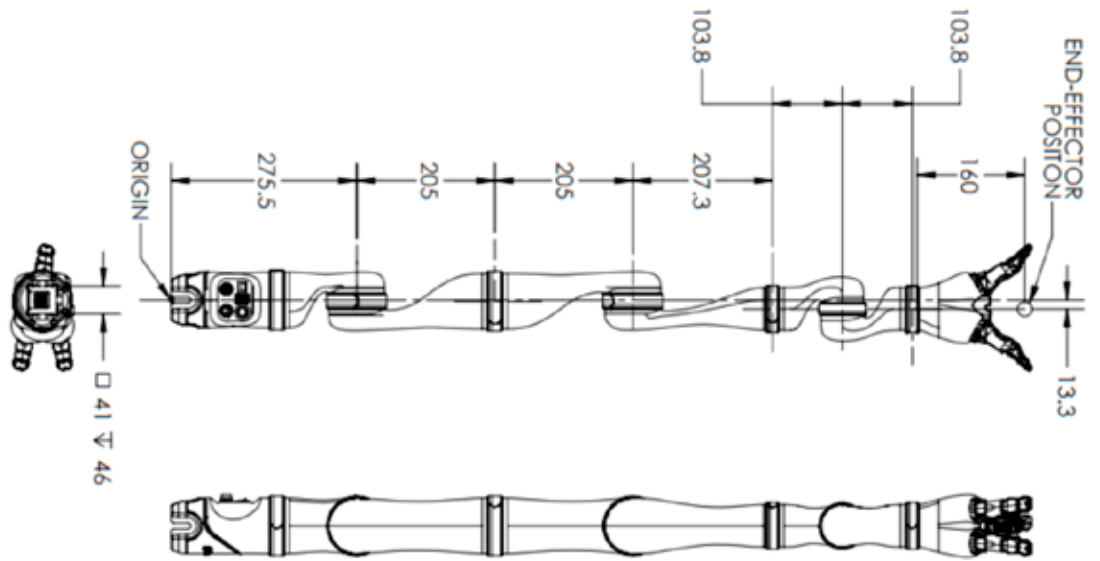

GENERAL

| | | NO GRIPPER | 2 FINGERS (KG-2) | 3 FINGERS (KG-3) |
|--|---------------------------|---|------------------|------------------|
| Total weight | | 5.5 kg | 5.98 kg | 6.18 kg |
| Payload capabilities | Mid-range continuous | 2.4 kg | 1.6 kg | 1.4 kg |
| | Full-reach peak/temporary | 2.1 kg | 1.3 kg | 1.1 kg |
| Materials | Links | Carbon fiber | | |
| | Actuators | Aluminum | | |
| Maximum reach | | 98.5 cm | | |
| Joint range after start-up <small>(software limitation)</small> | | ±27.7 turns | | |
| Maximum linear arm speed | | 20 cm/s | | |
| Power supply voltage | | 18 to 29 VDC, 24 VDC nominal | | |
| Peak power | | 100 W | | |
| Average power | Operating mode | 25 W | | |
| | Standby mode | 5 W | | |
| Communication protocol | | RS-485 | | |
| Communication cables | | 20 pins flat flex cable | | |
| Expansion pins | | 2 <small>(on communication bus)</small> | | |
| Water resistance | | IPX2 | | |
| Operating temperature | | -10 °C to 40 °C | | |

CONTROLLER

| | | |
|---------------------------------|-----------------------|------------------------------|
| Ports | Joystick | 1 Mbps Canbus |
| | Power supply | 18 to 29 VDC, 24 VDC nominal |
| | USB 2.0 (API) | 12 Mbps |
| | Ethernet (API) | 100 Mbps |
| Control system frequency | High level (API) | 100 Hz |
| | Low level (API) | Up to 500 Hz |
| CPU | | 360 MHz |
| SDK | APIs | High and low level |
| | Compatibility | Windows, Linux Ubuntu & ROS |
| | Port | USB 2.0, Ethernet |
| | Programming languages | C++ |
| Control | | Force, cartesian & angular |

SPECIFICATIONS

| | |
|----------------------------------|--------|
| Actuators #1, #2, #3, #4 | KA-75+ |
| Actuators #5, #6 & #7 | KA-58 |